



***The effect
of moisture on continuous polymerization of
thermoplastic polyurethane (TPU)***

Reporter: Xin Liu^a

Junying Zhang^a, Lutong Gan^b, Kunhuan Liang^b, Pengpeng Sheng^b
Beijing University of Chemical Technology^a
Jiangmen YingChuan Polyurethane material CO., LTD.^b

Date: 9.17.2012



Introduction





Introduction

TPU

the continuity of the reaction process

- Batch Method
- Poor repeatability
- Unstable performance
- Difficulties in late granulation

- Continuous Method
 - ✓ Good repeatability
 - ✓ Stable performance
 - ✓ High production efficiency
-



Introduction

- Reaction Principle

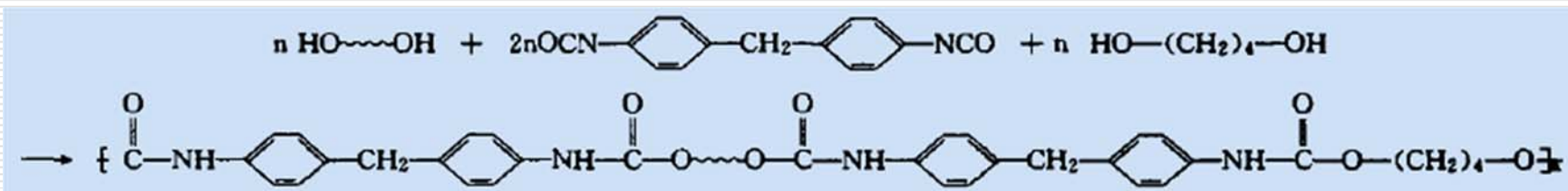

- Process Technique

Measurement

Conveying

Mixing

Reaction

Extruding

Pelletizing



Introduction

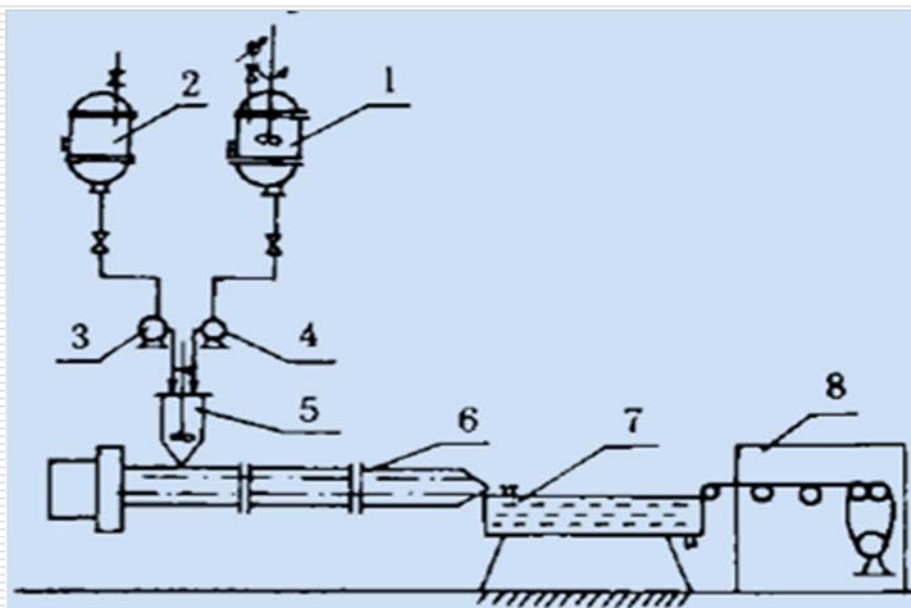

- Accurate measurement
 - Uniform mixing
 - Fixed reaction time and temperature
 - High quality
-



Background

- Influence Factors

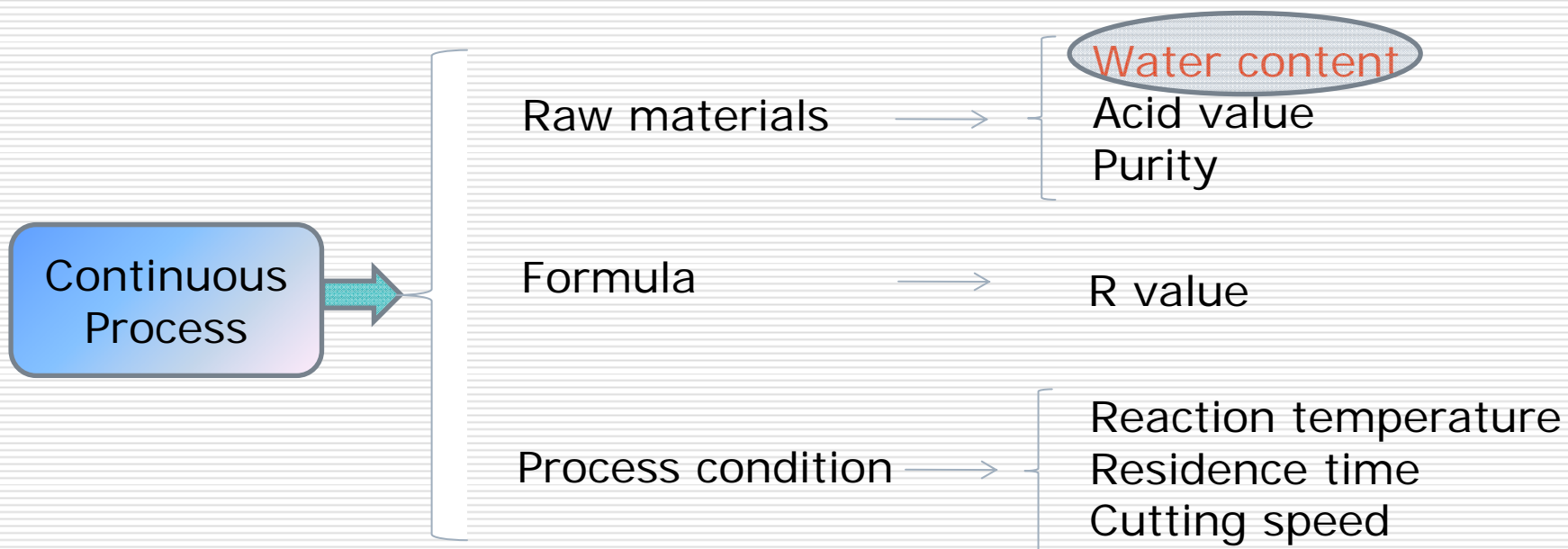



Experiment

1. Synthesis

C_h	Num.	Wd (g)	Wi (g)	Wg (g)	H_2O (ppm)
20%	1#	0.03	12.4	50	0
	2#	0.03	12.4	50	200
	3#	0.03	12.4	50	400
	4#	0.03	12.4	50	600

Note: C_h is the hard segment content; Wd is the quality of BDO; Wi is the quality of MDI; Wg is the quality of PBA.



Experiment

2.1 The effect of water content on TPU physical parameters

Number	Shore Hardness/A	Ring and Ball Softening Point/°C	MI/120°C、2.16kg
1#	75	115	8.5
2#	75	95	9
3#	75	89	22
4#	75	85	34

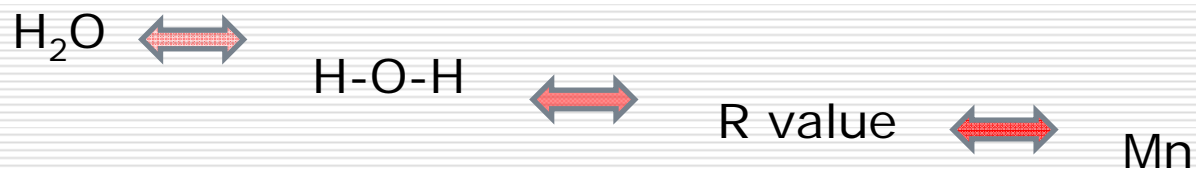



Experiment

2.2 The effect of moisture on TPU structure

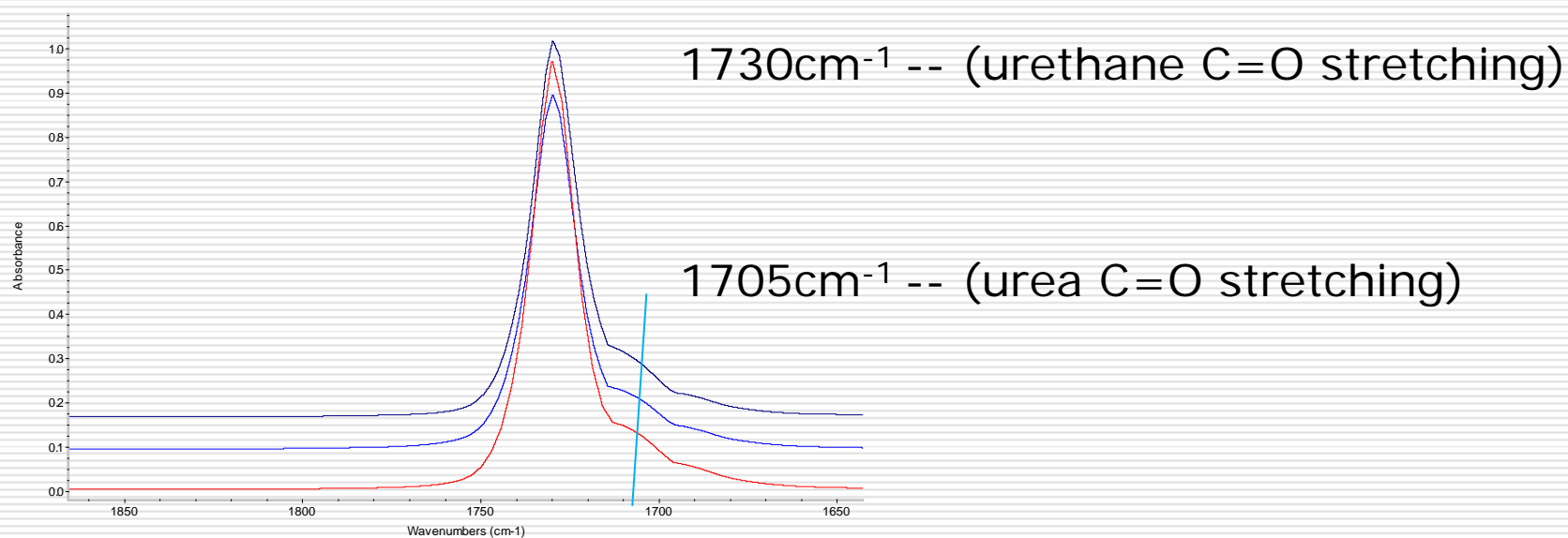

Fig.1. FTIR spectrum of TPU in different temperature.



Experiment

2.3 The effect of water content on Mn of TPU

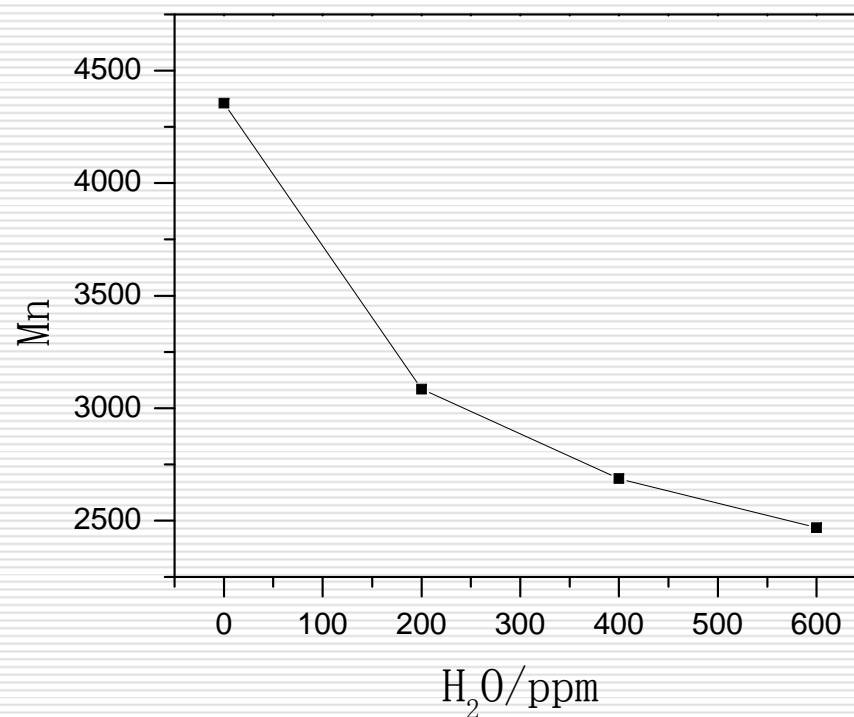

Fig.2. The relationship of water content and TPU Mn.

Conclusion

1. Water plays as extender in the process of continuous polymerization of TPU;
2. With the increase of water content, the softening point decreased, and the MI increased.

Fisheyes exist in the process, which are unexplained so far, still needs further research



THANKS
